

INNOVATIVE
TECHNOLOGY
WORLDWIDE

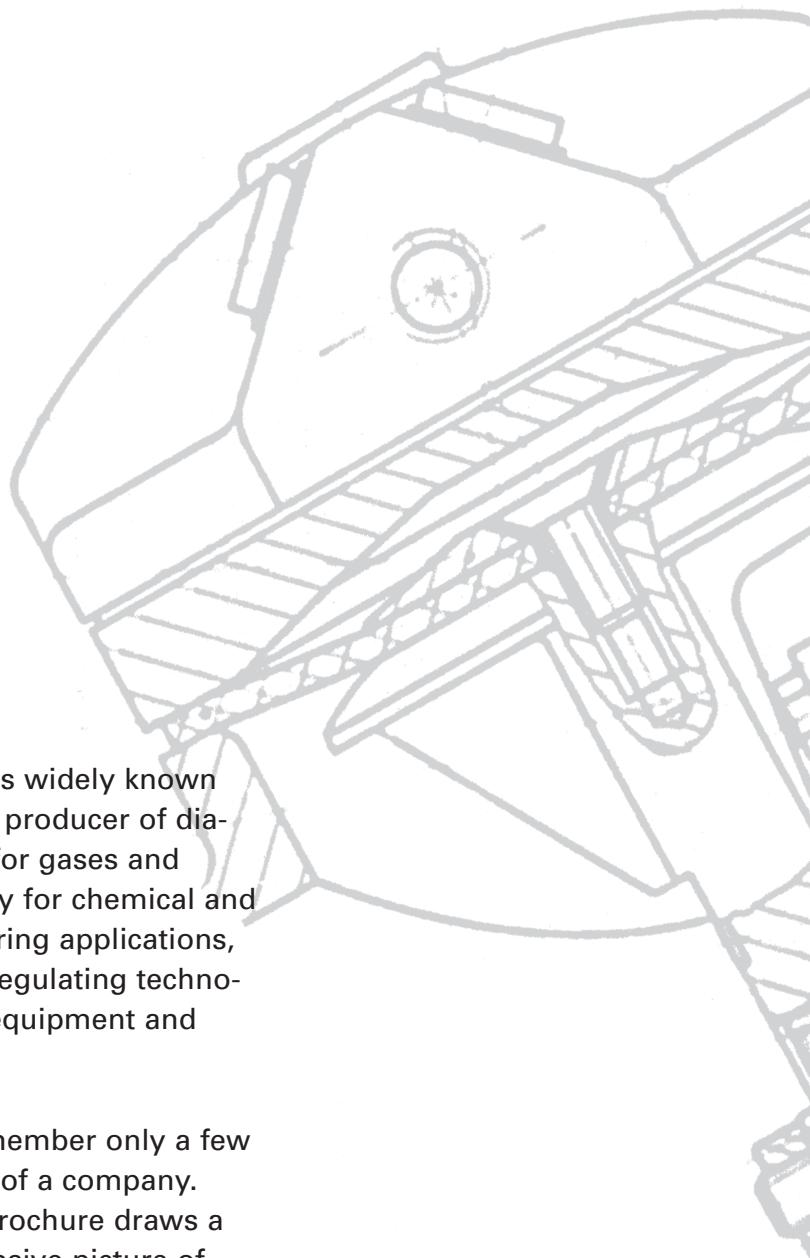

NEUBERGER



Diaphragm pump technology and systems



Prologue

KNF Neuberger is widely known as an innovative producer of diaphragm pumps for gases and liquids, especially for chemical and process engineering applications, measuring and regulating technologies, medical equipment and laboratories.

People often remember only a few technical details of a company. Therefore, this brochure draws a more comprehensive picture of the company than the day-to-day contact with clients and suppliers normally permits. The objective is to illustrate what KNF has achieved through forward thinking management and a committed workforce.





Looking back



*Kurt Neuberger
(1909-1966)*

Barely a year after the end of World War II, Kurt Neuberger established Kurt Neuberger KG (KNF) in Freiburg. The Company initially repaired engines, produced thread cutting machines and carried out contract work.

In 1962, Erich Becker joined the Company and diaphragm pumps were added to the range of products. Very soon after KNF Neuberger KG laid the foundation for its international presence when, in 1968, two years after Erich Becker succeeded the late Kurt Neuberger as managing director of the Company, KNF France was set up as the Company's first subsidiary.



Erich Becker



*KNF
Upright drill
(1961)*

Today, the worldwide KNF Neuberger Group comprises 15 companies with a total workforce of over 500 personnel.

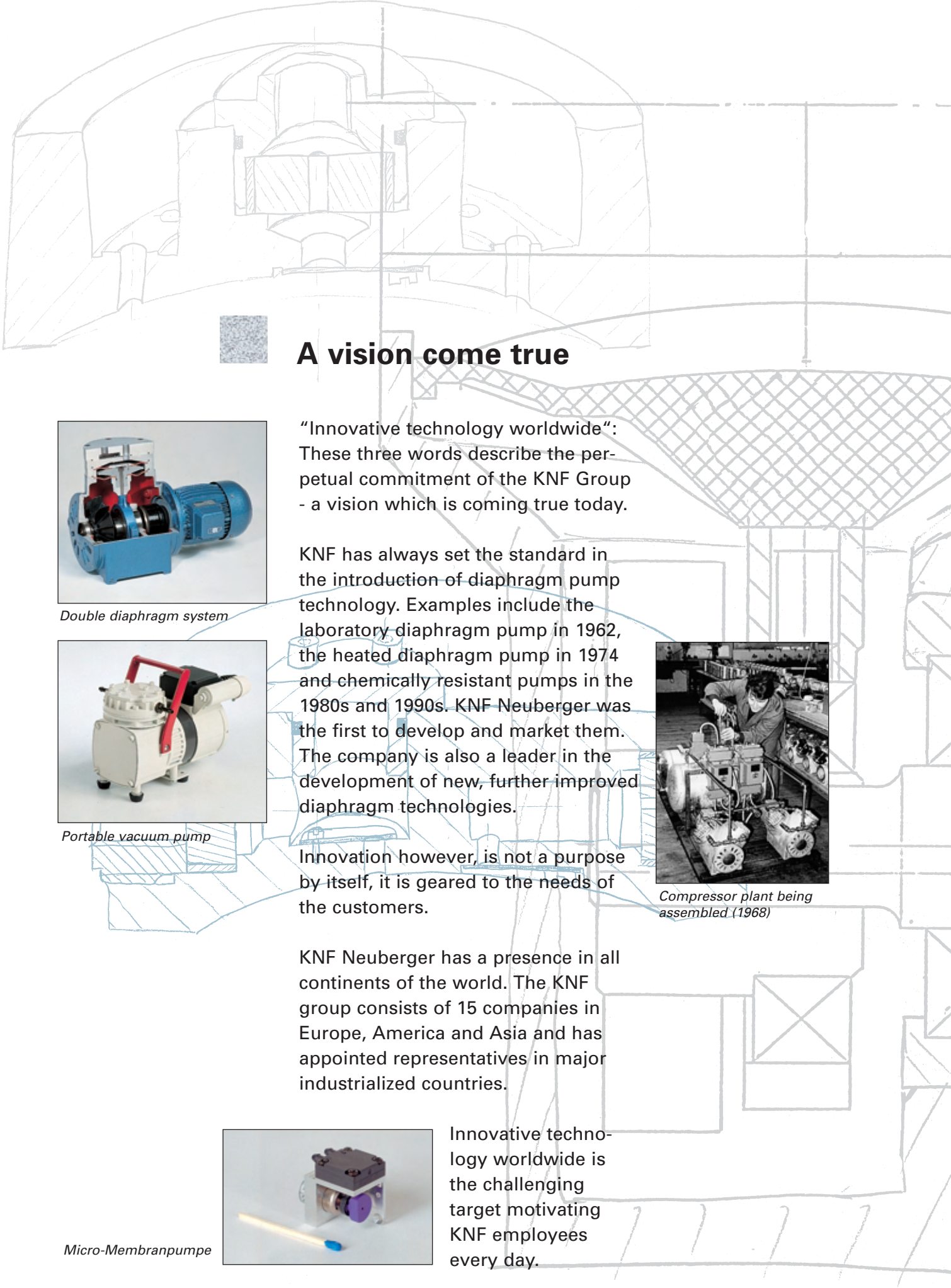

A vision come true

“Innovative technology worldwide”:
These three words describe the perpetual commitment of the KNF Group - a vision which is coming true today.

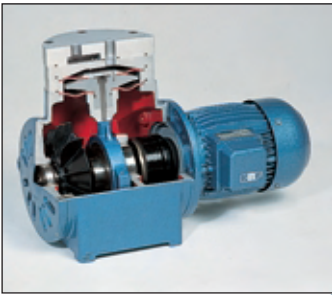

Double diaphragm system

KNF has always set the standard in the introduction of diaphragm pump technology. Examples include the laboratory diaphragm pump in 1962, the heated diaphragm pump in 1974 and chemically resistant pumps in the 1980s and 1990s. KNF Neuberger was the first to develop and market them. The company is also a leader in the development of new, further improved diaphragm technologies.



Portable vacuum pump

Innovation however, is not a purpose by itself, it is geared to the needs of the customers.



Compressor plant being assembled (1968)

KNF Neuberger has a presence in all continents of the world. The KNF group consists of 15 companies in Europe, America and Asia and has appointed representatives in major industrialized countries.

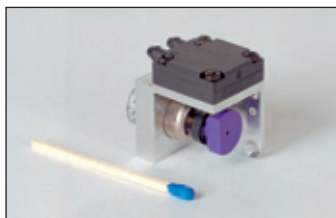

Micro-Membranpumpe

Innovative technology worldwide is the challenging target motivating KNF employees every day.

Ideas become reality

From development to production

Efficiency in product development permits KNF Neuberger to set technological standards.

Developing new products is the task of the various product centers:

- Pumps for gaseous media: KNF Neuberger (D)
- Pumps for liquid media: KNF FLODOS (CH)
- Motors for pumps: KNF Neuberger (F)
- Valves: KNF FLODOS (CH)

The product centers are responsible for their product groups from the initial development to the final product. Flexibility is a great asset within the KNF Group. Hence, production is not necessarily limited to a product center.

In the beginning, production was centered in an old factory building - now housing a cultural center known as the „factory“. Today, the KNF Group of companies have four state-of-the-art production centers worldwide: in Germany, France, Switzerland and America.



Until 1969: The parent of KNF Neuberger in Freiburg



KNF Neuberger GmbH, Freiburg



Pump assembly

Pump technology from a single source

KNF supplies a wide range of products, such as diaphragm pumps for gases or liquids, swing piston compressors and vacuum pumps, or valves.

KNF pumps are used in applications where

- gases and vapors must be transferred, evacuated or compressed or
- liquids must be transferred or metered.

To mention just a few features: KNF pumps are robust, need no maintenance and do not pollute the media they handle. They are very versatile and can be used in a multitude of applications, including the following areas:

- Medical equipment
- Environmental protection/ analytical technology
- Process engineering
- Food technology
- Print technology
- Energy technology
- Research



Chemically resistant gas transfer pump with ceramic heads



Multi head liquid pump



KNF diaphragm pressure control valves



Micro diaphragm gas sampling pump (actual size)

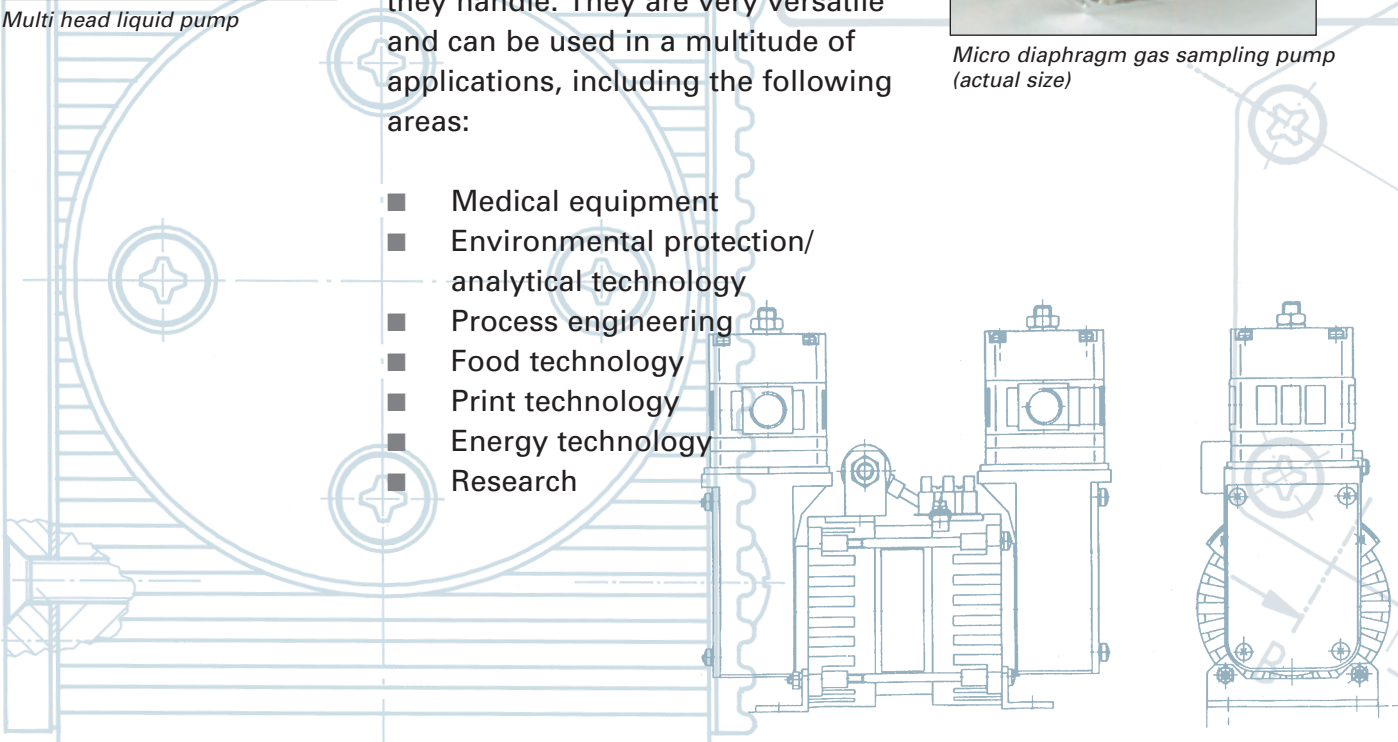



Compact OEM pumps for gases and liquids

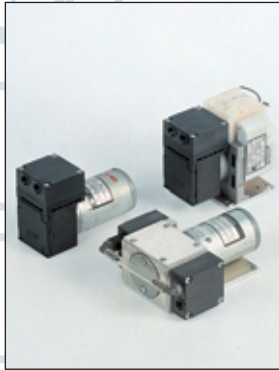

Roughing pump

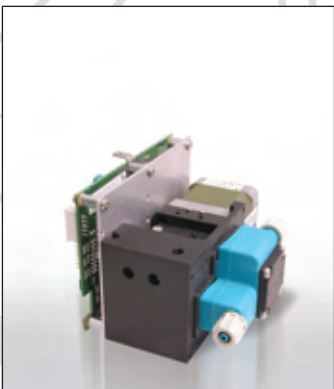

Metering OEM pumps



Modular vacuum system



Vacuum pump system with wireless remote control



Laboratory liquid pumps



Laboratory vacuum pump

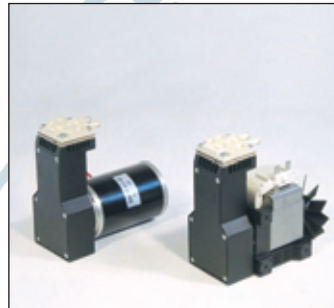

Swing piston pumps

The modular product profile...

In addition to pumps which are incorporated into equipment (so-called built-in or OEM pumps), KNF produces a wide range of portable pumps which are normally used in laboratories.

KNF diaphragm pumps are available in a range of different sizes and capacities. The smallest diaphragm pump weighs a mere 20 grams. The larger pumps can transfer up to 300 litres of gas per minute.



Metering pumps

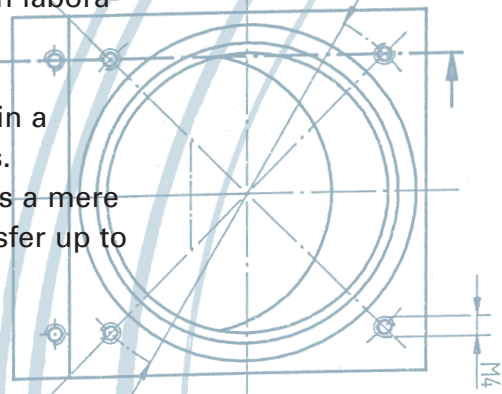

... for customized solutions

KNF's extensive product range, in conjunction with its modular system for pump heads and motors, make possible a high degree of flexibility. Based on 50 basic pump models, the KNF modular system actually increases the product range to 2,650 standard product types. Including the various voltage/frequency combinations available, 50

basic pumps provide over 23,400 standard models.



KNF pumps for different drive variants

Where customer requirements are outside the range of a standard product, KNF capabilities

include customized projects. To date, over 19,000 such projects have been successfully completed, as the modular system allows modifications to be carried out cost-effectively.

Larger projects, including completely new designs, are also part of the KNF routine.



Variety from the KNF modular system

KNF worldwide

The KNF Group (with year of foundation)

Germany: KNF Neuberger GmbH (1946)
 France: KNF Neuberger S.A. (1968)
 Italy: KNF Italia S.r.l. (1972)

USA: KNF Neuberger Inc. (1977)
 United Kingdom: KNF Neuberger U.K. Ltd. (1978)
 Switzerland: KNF-Neuberger AG (1979)
 Japan: KNF Japan Co. Ltd. (1983)
 Switzerland: KNF FLODOS AG (1988)
 Netherlands: KNF Verder B.V. (1991)
 Belgium: KNF Verder N.V. (1996)

Korea: KNF Neuberger Ltd. (1997)
 Taiwan: KNF Neuberger Ltd. (1999)
 Sweden: KNF Neuberger AB (2000)
 China: KNF Neuberger Trading Co., Ltd. (Shanghai) (2007)
 India: KNF Pumps+Systems Pvt. Ltd (2009)



KNF Neuberger

KNF Representatives (with year of appointment)

Spain: 1971
 Australia: 1973
 Austria: 1974
 South Africa: 1977
 India: 1984
 Czech Republic: 1985
 Slovakia: 1985
 Israel: 1989
 Croatia: 1992
 Poland: 1994
 Thailand: 1995
 Singapore: 1997
 Turkey: 1998
 New Zealand: 1999
 Malaysia: 2000
 Belarus: 2002
 Russia: 2004
 Vietnam: 2004
 Romania: 2008

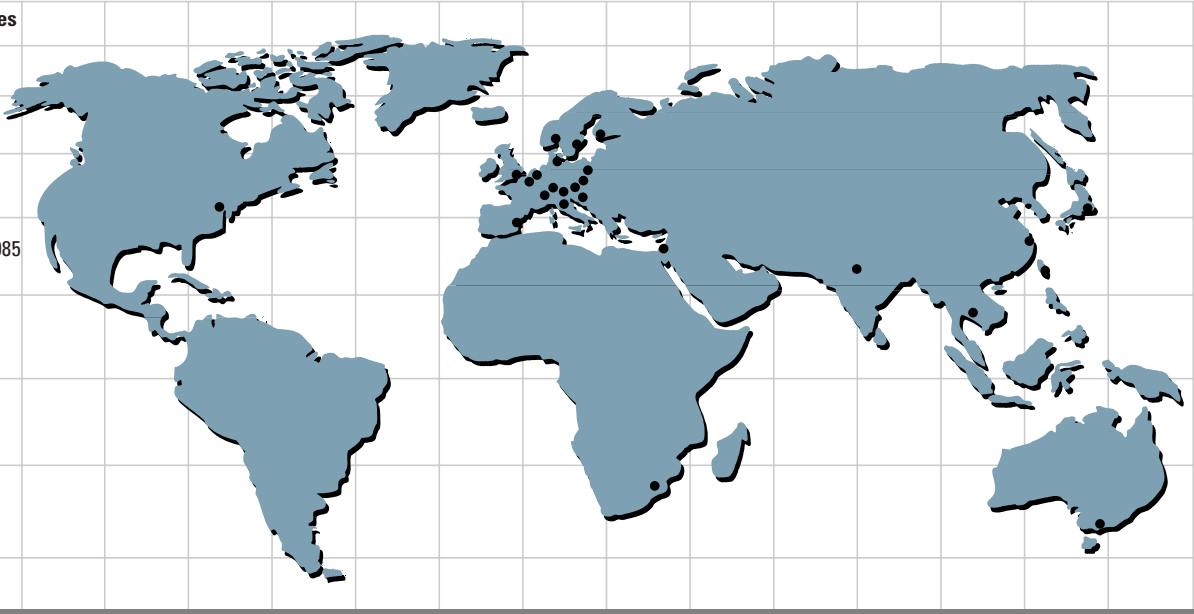

The economic success of KNF is ensured through its diversified worldwide presence. Subsidiaries which are engaged in production contribute to the success, as do the distribution companies and representatives. All are committed to the same principle: "Innovative technology worldwide".



KNF Neuberger GmbH, Germany



KNF Neuberger S.A., France



KNF Neuberger Inc., USA



KNF FLODOS AG, Switzerland



www.knf.com

